



Cross Agitators/Lagoon Mixers



Model	HP Needed	Length	Top Fill Option	Top Link
SA1	60 HP	7ft 8ft 9ft	Yes	Yes
SA2	60 HP	7ft 8ft 9ft	Yes	No
SW1 Tank Wall	60 HP	Any	No	No
SM 1 Lagoon Mixer	80 HP	4.6m 6.1m 7.6m	No	Yes
SW 2 Lagoon Mixer	120 HP	7.0m 8.0m 9.5m 12m	No	Yes
SW 3 Lagoon Mixer	80 HP	7.5m	No	Yes
Megamix	140 HP	7.0m 8.0m 9.5m 12m	YES	Yes

Cross Agricultural Engineering – “It’s the Obvious Choice”

The Cross SAI & SA2 Agitator Range

CROSS
AGRICULTURAL ENGINEERING

The Cross Agitator pump range is built to the highest standard by a team of dedicated engineers using quality materials and manufactured in the latest high-tech manufacturing facilities. The Cross SA1 and SA2 Agitators are the most powerful and highest output agitators on the market today, with there built in chopper units, 5000 litres/min output and with power requirements of 60HP upwards this makes the cross agitator range the obvious choice on the market today.

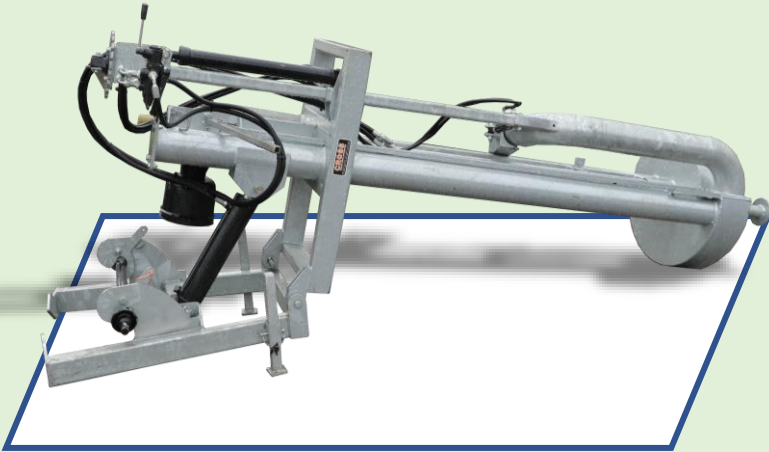

SA1 Agitator Pump

The Cross SA1 Agitator is made entirely of 6" pipe for high output. This model of slurry pump is designed entirely for the farmer with only one tractor. It can be disconnected from while in the tank and a top link is not needed to attach to the agitator. Any tractor from 60Hp up can handle this machine due to the different ratio gearboxes provided by Cross Agricultural Engineering. All Cross Agitator Pumps cannot block with round bale silage due to the shear bar chopping unit fitted to the base of the pump. The range of Cross pumps are the highest output pumps on the market.

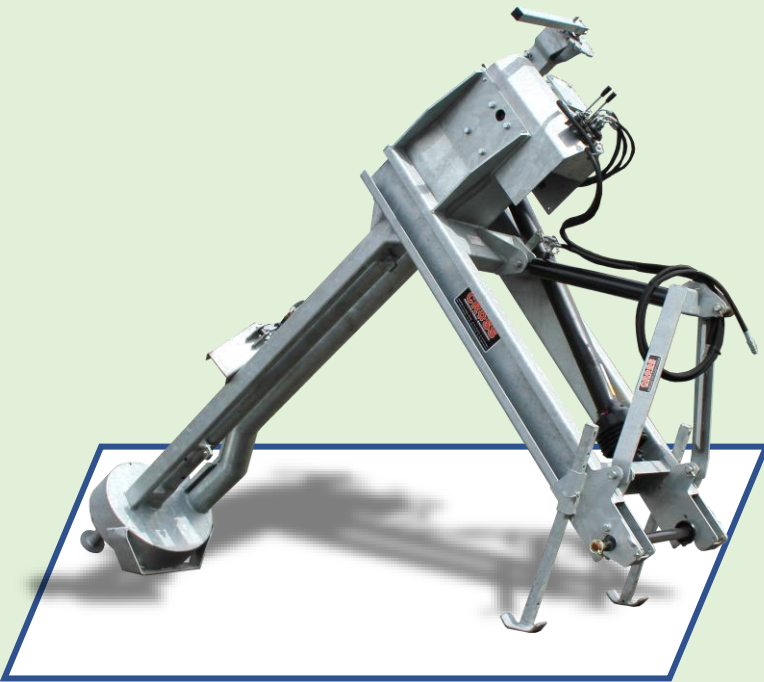

SA2 Agitator Pump

The Cross SA2 Agitator is also made entirely of 6" pipe for high output. This model of slurry pump is designed for the farmer or contractor with numerous tanks to agitate. This agitator can be moved tank to tank with the PTO left connected. Any tractor from 60Hp up can handle this machine due to the different ratio gearboxes provided by Cross Agricultural Engineering. All Cross Agitator Pumps cannot block with round bale silage due to the shear bar chopping unit fitted to the base of the pump. The range of Cross pumps are the highest output pumps on the market.



Cross Agricultural Engineering – “It’s the Obvious Choice”



The Cross SA1 & SA2 Agitator Range

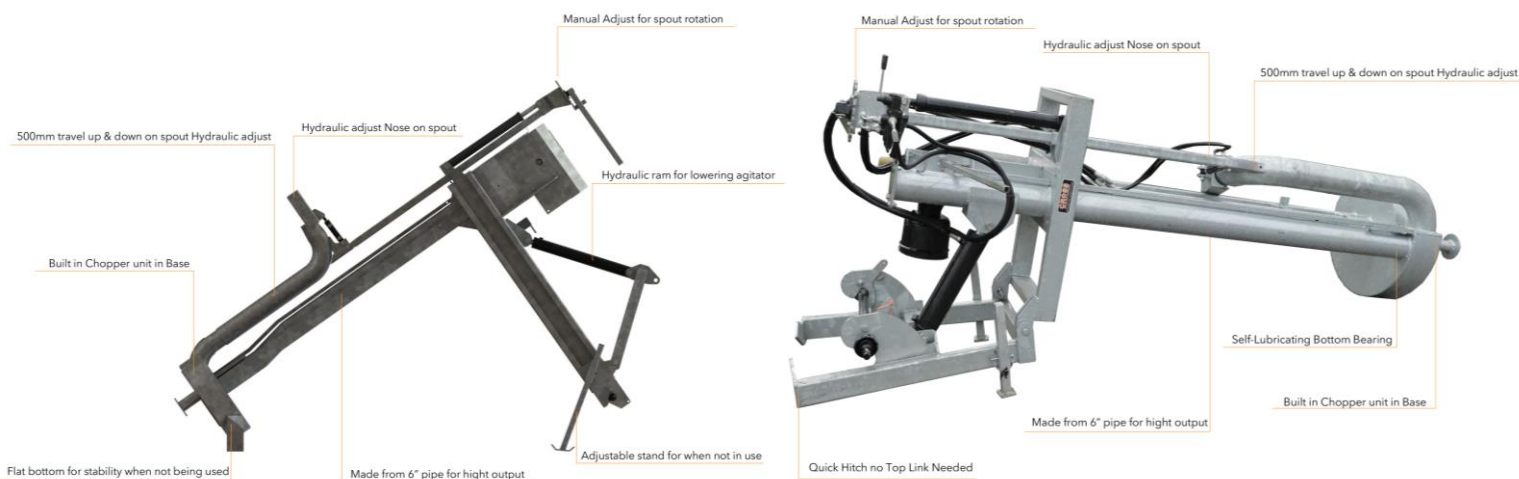

Shear Bar Chopping

The Cross SA1 & SA2 Agitator Pumps cannot block with round bale silage due to the chopping unit in the bottom of the pump. The impellor on the pump is also sharpened to a razor-sharp edge to help with the chopping, with the added advantage of the hydraulic adjustment on the nose of the output spout you can tilt the nose downwards to drive the tick lumps towards the agitator base and chopper to unit to quickly break up stubborn solids. Unlike most pumps you can replace the shear bar if necessary. The shaft is also shear bolt protected so any foreign objects don't damage the pump when getting pulled into the chopping unit.

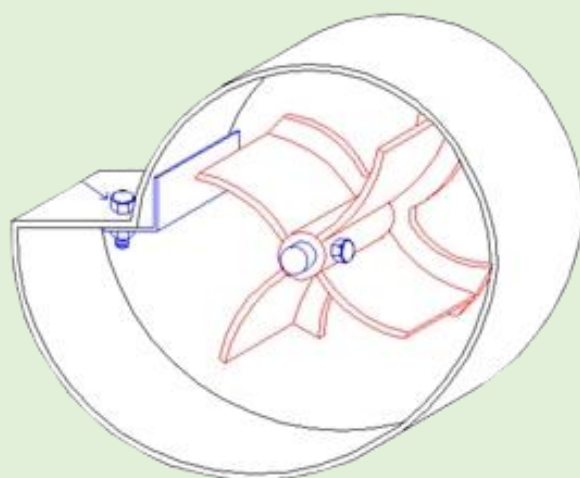

- **5000 Litre/Min Output**
- **Built in Chopper Unit**
- **Sheer bolt Protected**
- **Fully Galvanised**
- **Heavy Duty Gearbox**
- **Self- Lubricating Bottom Bearing**
- **2 Bank Valve**
- **Low Power Requirements**
- **Full Spout Movements**

Agitators	SA1	SA2
HP Needed	60HP Plus	60HP Plus
Length	7ft - 8ft - 9ft	7ft - 8ft - 9ft
Top Fill Option	Yes	Yes
Top Link	No	No
Weight	660KG	720KG
Overall Height	1.27m	2.15m
Overall Length	3.53m	3.53m
Overall Width	0.91m	0.91m

Cross Agricultural Engineering – “It’s the Obvious Choice”



The Cross Lagoon Mixer Range



The Cross Lagoon Mixer range is built to the highest standard by a team of dedicated engineers using quality materials and manufactured in the latest high-tech manufacturing facilities. The Cross Lagoon Mixers are some of the most powerful and highest output Lagoon mixers available, with their Verity in sizes and 600mm plus propeller the Cross Lagoon mixers are the obvious choice on the market today.

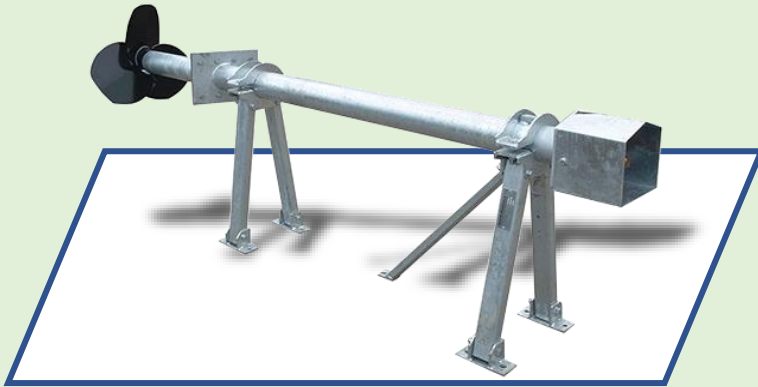

SW1 Wall Mixer

The Cross SW1 Mixer is a Tank Wall Mixer. This model is used for mixing over ground tanks. It is fitted permanently in the tank wall and is fixed to the ground. The machine is relatively easy to drive with 60 – 70HP Required and mixing is rated at 540rpm on full tanks. All Cross Tank Wall Mixers come complete fully Galvanised and have a output capacity of 1200m³ from one mixing point.

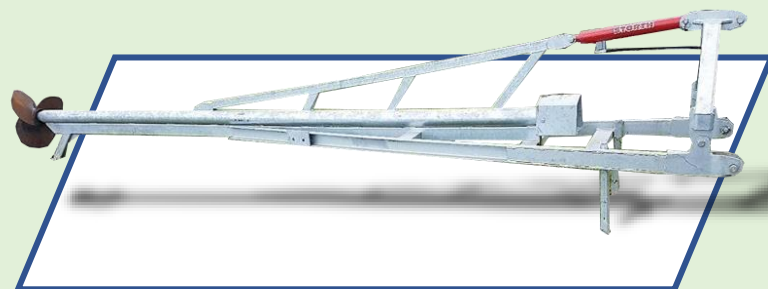

SM1 Lagoon Mixer

The Cross SM1 Lagoon Mixer is a high output Lagoon Mixer for mixing tanks of various size. The SM1 Model comes fully Galvanized and is made with a heavy-duty box section to strengthen the mixing tube. The SM1 has a Hydraulic depth adjustable ram to allow the ease of control and positioning when Lagoon mixing. The Cross SA1 mixer is fitted with a 600mm Heavy duty propeller, 2" Block hose bearing assembly and is rated for 60 -70 HP with make this one of the leaders in the market.

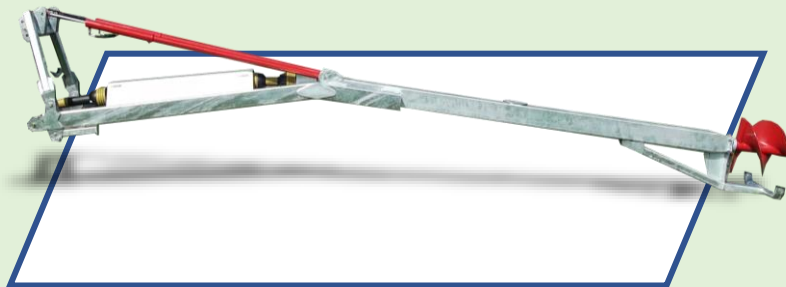

SW2 Wall Mixer

The Cross SW2 Lagoon Mixer is a high output machine for mixing large tanks of various sizes. This machine was developed for larger lagoons. The SW2 has a Hardox shear bar attached for cutting any fiber content that may become entangled in the shaft, the shaft is shear bolt protected and has easy access grease points to help the longevity of the 5 50mm bearing assembly. The SW2 is fitted with either a 600mm or 700mm Propeller for high output mixing. The Hydraulic ram controls mixing depth and the Cow horn leg prevents lagoon liner damage when positioning into the Lagoon.

The Cross Lagoon Mixer Range



The Cross Lagoon Mixer range is built to the highest standard by a team of dedicated engineers using quality materials and manufactured in the latest high-tech manufacturing facilities. The Cross Lagoon Mixers are some of the most powerful and highest output Lagoon mixers available, with their Verity in sizes and 600mm plus propeller the Cross Lagoon mixers are the obvious choice on the market today.

SW3 Wall Mixer

The Cross SW3 Mixer is a high output machine for mixing specialized tanks built for easy mixing. This machine was developed for rotary tanks that can be easily made flow with the right machine. The SW3 is lowered into the tank on a set of specially built rails through a specific opening into the tank. This agitator also has a reverse gearbox fitted for making the tank flow in different directions. The SM1 has a 600mm Propeller and requires between 60 – 70HP to run

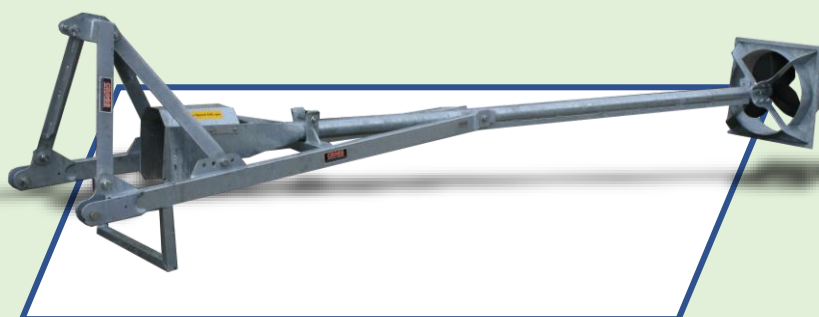

Mega Mixer

The Cross Mega Mixer is a high output lagoon mixer for mixing large tanks faster and more effectively. This mixer has a rotating jetter nozzle that can rotate 300° meaning you can do a lot more mixing from one point in the tank. The Mega Mixer has all 6" pipes for high output. You also have the option of using a top fill attachment on this machine for filling into other tanks if needs be. A trailer can also be purchased for moving this machine around to avoid large tail swing. This machine requires at least 140hp to operate.

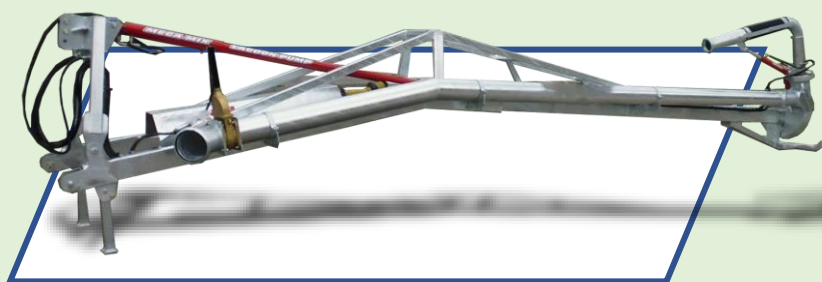

Cross Agricultural Engineering – “It’s the Obvious Choice”



The Cross Lagoon Mixer Range

Cross Agricultural Engineering – Lagoon Mixer – Specifications

Lagoon Mixer	SW3	SM1	SW2	Mega mix
HP Needed	60HP Plus	70HP Plus	80HP Plus	120HP Plus
Length	7.5m	4.6m – 6.1m – 7.6m	7.0m – 8.0m – 9.5m – 12.0m	7.0m – 8.0m – 9.5m
Mixing Capacity	1500m ³	3000m ³	4000m ³	10.000m ³
Propeller	600m	650m	600m	Inlet auger
Overall Height	1.34m	1.40m	1.40m	1.62m
Overall Weight	1.10m	1.10m	1.10m	1.00m



The Leaders in Slurry Mixing Equipment

Cross Agricultural Engineering is the result of 5 generations of metalworking skills within the Cross Family. This heritage has provided a solid foundation for manufacturing.

This literature is designed for worldwide circulation. Due to continuing policy of product improvement, we reserve the right to alter specifications and constructions without notice. As machines are exported to many different countries, general information, pictures and descriptions are provided; these should be taken as approximate and may include optional equipment that is not part of the standard specification. Please consult your local dealer/distributor for further information.

Cross Agricultural Engineering Ltd.,
Newtown, Rathangan,
Co.Kildare
R51 WR98
Ireland



Tel: 00353 (0) 45 524134

Fax: 00353 (0) 45 524631

Email: info@crossagrieng.ie

Website: www.crossagrieng.ie

Cross Agricultural Engineering – “It’s the Obvious Choice”